

### 7005/8005 Sod Cup Kit

The 7005/8005 Sod Cup Kit allows users to grow turf on the cap of the 7005 and 8005 rotors. This allows for a nearly invisible installation for applications such as sportsfields. The rugged construction of the 7005/8005 Sod Cup Kit provides maximum durability while maintaining maximum player safety.

#### Features

- Five year trade warranty
- Covers rotor cap with turf for an “invisible” installation
- Simple installation, snaps together without any special tools
- Rubber construction for maximum player safety
- Two piece design
  - Outer cup prevents debris intrusion during operation
  - Inner cup provides concealed turf growing area
- Integral pull up slot
- Easy arc adjustment after installation through inner cup
- Drain holes to promote healthy turf growth
- Works with either the 7005 or 8005 rotors

#### Dimensions

- Outer Cup Outside Diameter: 3.9 in (9,9 cm)
- Inner Cup Outside Diameter: 3.4 in (8,6 cm)
- Outer Cup Height: 4.3 in (10,9 cm)
- Inner Cup Height: 2.7 in (6,9 cm)
- Overall Height of 7005 or 8005 with Sod Cup Kit installed: 12.6 in (32,0 cm)



#### How to Specify

**SODCUP**

**Model**

Sod Cup Kit



## Specifications

The full- or part-circle sprinkler shall be a single stream, water lubricated, gear drive type capable of covering a \_\_\_\_ foot (meter) radius at a base pressure of \_\_\_\_ pounds per square inch (Bars) with a discharge rate of \_\_\_\_ gallons per minute (l/h, m<sup>3</sup>/h).

The sprinkler shall be capable of both full circle and part circle operation in the same unit. The mode of operation shall be selected by inserting a flat blade screwdriver in the top of the rubber cap and turning a selector approximately 45 degrees. The sprinkler shall not reverse direction during continuous operation in the full circle mode. The part-circle sprinkler shall have adjustable arc coverage of 50 to 330 degrees. Arc adjustment can be performed with or without the rotor in operation and shall require only a flat blade screwdriver. The arc adjustment can be performed on both the right and left trip of the sprinkler. The sprinkler shall have a rotating nozzle turret independent of the riser stem. The portion of the riser stem that is in contact with the wiper seal shall be non-rotating.

The sprinkler shall have a non-strippable drive mechanism and permit manual rotation of the pop-up stem in any direction. This shall have no effect on either the drive or the set arc. Once the manual rotation is terminated, the sprinkler shall automatically return the water stream to its preset arc.

The sprinkler shall have a pressure activated, multi-function, soft elastomeric wiper seal. This wiper seal shall prevent the sprinkler from sticking in the up position, and be capable of sealing the sprinkler riser stem to the sprinkler cap under normal operating pressures.

The sprinkler shall have a screen attached to the drive housing to filter inlet water, protect the drive from clogging and simplify its removal for cleaning and flushing of the system. The sprinkler body shall have a 1" (26/34) female (NPT or BSP) bottom inlet. The sprinkler shall have a standard rubber cover which designates each adjustment opening from the top. The sprinkler shall have a two piece, front-load nozzle assembly which will allow the nozzle to be installed without a stator bushing change. The primary and secondary nozzle ports shall be contained in one of the parts and shall be unique to each nozzle size. The tertiary nozzle port shall be common to all of the other primary/secondary nozzle assemblies. The sprinkler shall have a selection of eight color-coded nozzles. All but the #4 and #6 nozzles shall have three ports for optimal close-in, mid-range and long-range water distribution. The sprinkler shall have a stainless steel nozzle retention screw. The angle of trajectory shall be 25 degrees from horizontal.

The sprinkler shall have a strong stainless steel retract spring for positive pop-down. The sprinkler shall have a standard Seal-A-Matic™ (SAM) device capable of holding up to 10 feet (3,1 m) of head. Pop-up height as measured from the top of the cover to the centerline of the nozzle orifice shall be at least 5 inches (12,7 cm). The sprinkler's overall height shall be 10½ inches (25,7 cm) and the exposed diameter shall be 1⅞ inches (4,8 cm).

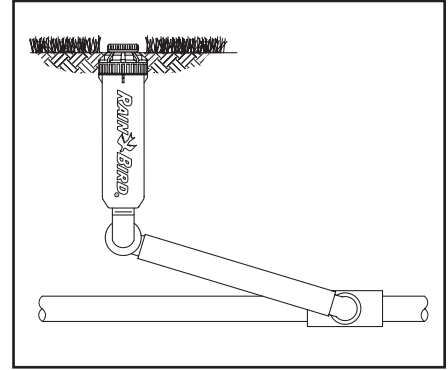

## 7005-SS

When so indicated on the design, the rotor shall have a stainless steel covered nozzle turret and riser stem. The riser stem shall be tapered and conform to the standard plastic riser in all other ways.

## Sod Cup Kit

The sprinkler shall include a sod cup kit with integral drain holes for growing natural turf on the rotor cover. The sod cup kit shall be a two piece design that will prevent debris intrusion/accumulation during pop up and retract cycles. The sod cup kit shall be easily removable without the use of special tools. The sod cup kit shall have two arc adjustment access holes at the bottom of the inner cup.

The sprinkler shall be as manufactured by Rain Bird Corporation, Glendora, California.

### Rain Bird Corporation

6991 E. Southpoint Road, Tucson, AZ, 85706, U.S.A.  
Phone: (520) 741-6100 Fax: (520) 741-6522

### Rain Bird Corporation

970 W. Sierra Madre Avenue, Azusa, CA, 91702, U.S.A.  
Phone: (626) 812-3400 Fax: (626) 812-3411

### Rain Bird International, Inc.

P.O. Box 37, Glendora, CA, 91740-0037, U.S.A.  
Phone: (626) 963-9311 Fax: (626) 852-7343

### Technical Service and Support

(800) RAINBIRD (U.S. and Canada only)

### Specification Hotline

(800) 458-3005 (U.S. and Canada only)

[www.rainbird.com](http://www.rainbird.com)

The Intelligent Use of Water™ -- Visit [www.rainbird.com](http://www.rainbird.com) to learn about our efforts

® Registered trademark of Rain Bird Corporation.  
© 2006 Rain Bird Corporation 9/06

D37409